

PARAT ORO

Multi Nozzle Lance for ORO tank heating



PARAT ORO: Multi Nozzle Lance for ORO tank heating

Technical data



In case of oil pollution to the sea surface, the oil will be recovered and stored in tanks in the oil recovery ships until it can be delivered to recovery stations on land. Experience from such situations has shown that the oil must be heated to maintain a sufficient viscosity for offloading. To ensure that the recovery vessels can operate efficiently, NOFO (Norsk Oljevernforening For Operatørselskap) have made regulations requiring a sufficient heating system for the tanks on board. Presently, such oil tanks are heated by steam from a boiler on board. The steam is in many cases delivered to several nozzles installed around the perimeter of the tank. To achieve an adequate distribution of steam and heat in the tank multiple nozzles must be installed.

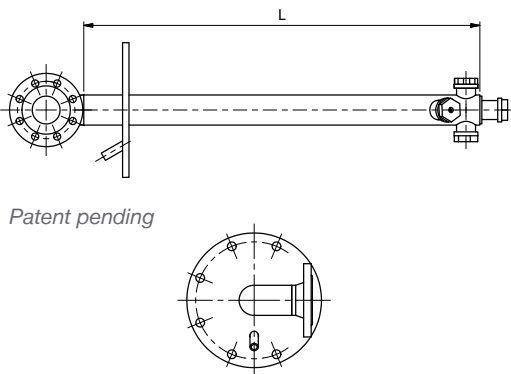

Patent pending

Such an installation has several drawbacks. One is the necessity of many openings in the tank. Another is the need of a manifold to distribute the steam. Both these features lead to a lot of couplings and gaskets that may develop leaks, and which are costly. Even with several nozzles installed, the heat distribution may be insufficient, leaving spaces such as the area around the tap in the bottom of the tank, in a cold shadow. There may also be insufficient room in the ship around the tank for such a large installation with manifolds etc., in particular when retrofitting an existing tank. Often the tank is accessible only in a small sector of its circumference, making it difficult to provide a sufficient number of steam inlets. Parat Halvorsen has provided a multi nozzle arrangement that gives a better distribution of heat in an oil recovery tank, and at a lower cost than prior art installations. An additional advantage is a nozzle arrangement that is robust and is more insensitive to damages than existing arrangements.

- Only one flange in each tank
- Very good distribution of steam
- Direct distribution of steam to pump suction area
- All components in SS 316L

This is achieved with a distribution system which is capable of heating the whole tank from one insertion point. This makes the installation of the heating system much more efficient. The arrangement reduces the need for complicated assemblies in the tanks, and also ensures that it is sufficient with one nozzle system pr. tank. Parat Halvorsen has thus far delivered more than 20 ORO Systems to domestic and international clients, and with a continuous focus on improvements and development we strongly believe that we will experience an increasing success with this product in the years to come.

